

# Technical data sheet



## Product features

### Cooling counter GN 1/1 pizza 2x door, 7x drawer

<b>Model</b>	<b>SAP Code</b>	00014286
RTP 3D-2D7ZN	<b>A group of articles - web</b>	Cooling and freezing tables



- Material: Stainless steel
- Number of doors: 2
- Number of drawers: 7
- Control type: Digital
- Minimum device temperature [°C]: -2
- Maximum device temperature [°C]: 8
- Max ambient temperature [°C]: 43
- Insulation thickness [mm]: 50
- Unit: Right

<b>SAP Code</b>	00014286	<b>Number of doors</b>	2
<b>Net Width [mm]</b>	2017	<b>Number of drawers</b>	7
<b>Net Depth [mm]</b>	800	<b>Minimum device temperature [°C]</b>	-2
<b>Net Height [mm]</b>	850	<b>Maximum device temperature [°C]</b>	8
<b>Net Weight [kg]</b>	340.00	<b>Refrigerant</b>	R290
<b>Power electric [kW]</b>	0.247	<b>Worktop material</b>	Granite
<b>Loading</b>	230 V / 1N - 50 Hz	<b>Refrigerant weight [g]</b>	105.00
<b>Energy class</b>	D	<b>Climate class</b>	4
<b>Chamber volume [l]</b>	372		

# Technical data sheet



Technical drawing

Cooling counter GN 1/1 pizza 2x door, 7x drawer

<b>Model</b>	<b>SAP Code</b>	00014286
RTP 3D-2D7ZN	<b>A group of articles - web</b>	Cooling and freezing tables

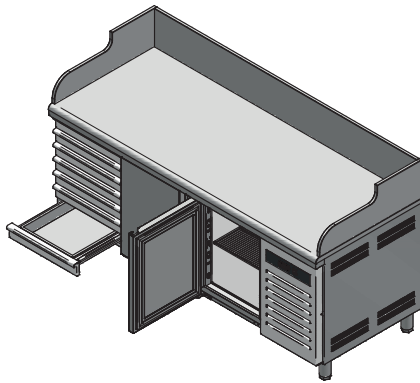
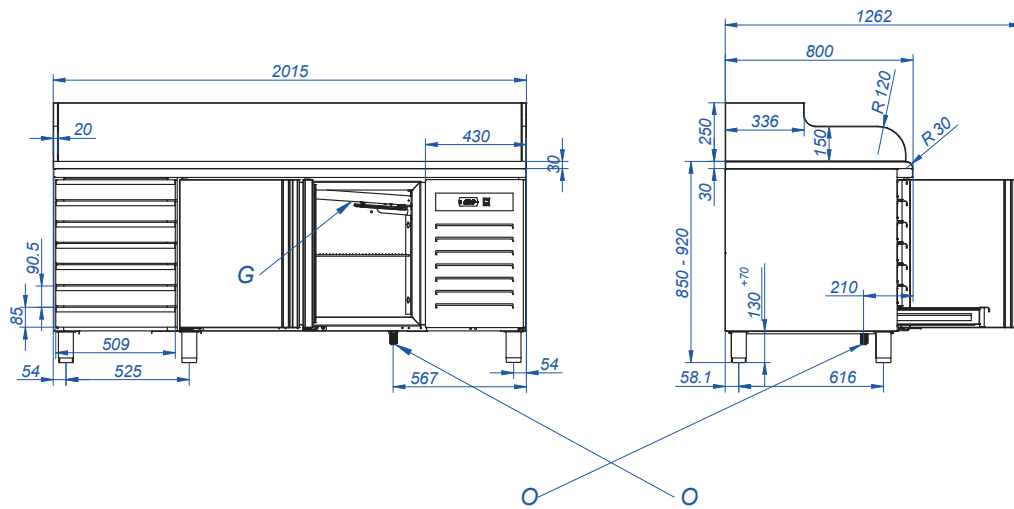

# Technical data sheet



## Technical parameters

### Cooling counter GN 1/1 pizza 2x door, 7x drawer

<b>Model</b>	<b>SAP Code</b>	00014286
RTP 3D-2D7ZN	<b>A group of articles - web</b>	Cooling and freezing tables

**1. SAP Code:**

00014286

**2. Net Width [mm]:**

2017

**3. Net Depth [mm]:**

800

**4. Net Height [mm]:**

850

**5. Net Weight [kg]:**

340.00

**6. Gross Width [mm]:**

2075

**7. Gross depth [mm]:**

840

**8. Gross Height [mm]:**

1085

**9. Gross Weight [kg]:**

355.00

**10. Device type:**

Electric unit

**11. Power electric [kW]:**

0.247

**12. Loading:**

230 V / 1N - 50 Hz

**13. Energy class:**

D

**14. Refrigerant:**

R290

**15. Cooling type:**

Dinamic

**16. Material:**

Stainless steel

**17. Min ambient temperature [°C]:**

10

**18. Max ambient temperature [°C]:**

43

**19. Device properties 2:**

Cooling

**20. Chamber volume [l]:**

372

**21. Worktop material:**

Granite

**22. Adjustable feet:**

Yes

**23. Pizza design:**

Yes

**24. Insulation thickness [mm]:**

50

**25. Number of doors:**

2

**26. Number of drawers:**

7

**27. Unit:**

Right

**28. Control type:**

Digital

# Technical data sheet



Technical parameters

## Cooling counter GN 1/1 pizza 2x door, 7x drawer

<b>Model</b>	<b>SAP Code</b>	00014286
RTP 3D-2D7ZN	<b>A group of articles - web</b>	Cooling and freezing tables

### 29. HACCP:

Yes

### 33. Gross Volume [m3]:

1.891

### 30. Minimum device temperature [°C]:

-2

### 34. Net Volume [m3]:

1.372

### 31. Maximum device temperature [°C]:

8

### 35. Climate class:

4

### 32. Refrigerant weight [g]:

105.00

### 36. Cross-section of conductors CU [mm<sup>2</sup>]:

0,5